

Technical Data

Specifications & Capacities

RTC 8065

Series II

Telescopic Boom Truck Crane

60.0 metric ton

CE

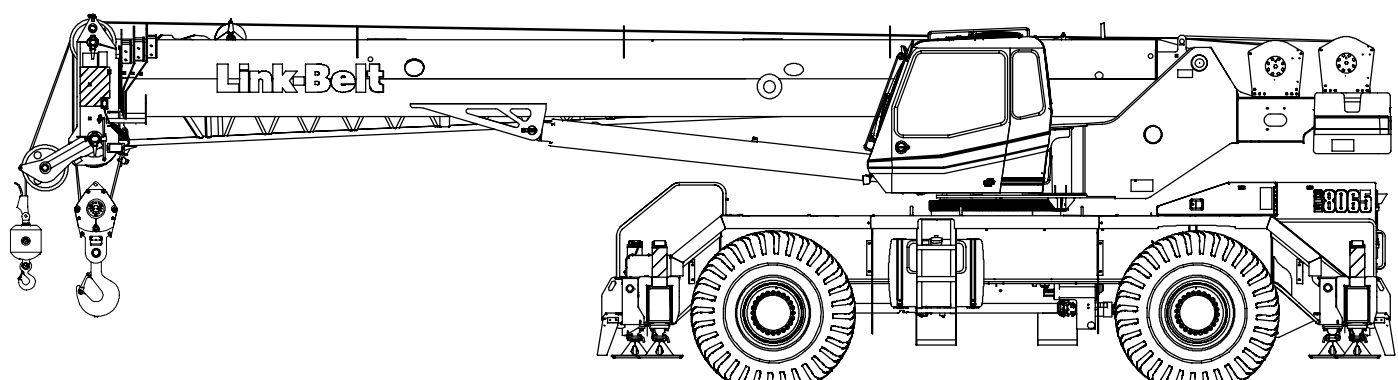

CAUTION: This material is supplied for reference use only. Operator must refer to in-cab Crane Rating Manual and Operator's Manual to determine allowable crane lifting capacities and assembly and operating procedures.

Table Of Contents

Boom, Attachments, and Upper Structure	1
Boom	1
Boom Head	1
Boom Elevation	1
Auxiliary Lifting Sheave – Optional	1
Hook Blocks and Balls – Optional	1
Fly – Optional	1
Fly Inserts – Optional	1
Operator’s Cab and Controls	1
Swing	2
Electrical	2
Load Hoist System	3
Load Hoist Performance	3
2M Main and Optional Auxiliary Winches	3
Hydraulic System	3
Counterweight	3
Carrier	4
General	4
Outriggers	4
Steering and Axles	4
Suspension	4
Tires and Wheels	4
Brakes	4
Electrical	4
Engine	4
Transmission	4
Carrier Speeds and Gradeability	5
Fuel Tank	5
Hydraulic System	5
Pump Drive	5
Axle Loads	6
General Dimensions	7
Working Range Diagram	8
Boom Extend Modes	9
Main Boom Lift Capacity Charts – Standard	10
Fully Extended Outriggers – 360° Rotation	10
On Tires – Stationary – Boom Centered Over Front Between Tire Tracks	11
On Tires – Pick & Carry (Creep) – Boom Centered Over Front	12
On Tires – Stationary – 360° Rotation	12
Fly Attachment Lift Capacity Charts – Optional	13
Fully Extended Outriggers – 360° Rotation	13
35.05 m Main Boom Length – 2° Fly Offset	13
35.05 m Main Boom Length – 15° Fly Offset	13
35.05 m Main Boom Length – 30° Fly Offset	14
35.05 m Main Boom Length – 45° Fly Offset	14

Boom, Attachments, and Upper Structure

■ Boom

Design – Four section, formed construction of extra high tensile steel consisting of one base section and three telescoping sections. The first telescoping section extends independently by means of one double-acting, single stage hydraulic cylinder with integrated holding valves. The second and third telescoping sections extend proportionally by means of one double-acting, single stage cylinder with integrated holding valves and cables.

Boom

- 11.6–35.0m (38–115 ft) four section full power boom
- Two mode boom extension: *A-max* mode provides superior capacities by extending the first telescoping section to 19.4m (63 ft 8 in). Standard mode synchronizes all the telescoping sections proportionally to 35.0m (115 ft). Controlled from the operator's cab.
- Mechanical boom angle indicator
- Maximum tip height for *A-max* mode is 22.4m (73 ft 6 in) and standard mode is 37.7m (123 ft 9 in).

Boom Head

- Four 419mm (16.5 in) root diameter nylon sheaves to handle up to eight parts of line
- Easily removable wire rope guards
- Rope dead end lugs on each side of the boom head
- Boom head is designed for quick-reeve of the hook block

Boom Elevation

- One double acting hydraulic cylinder with integral holding valve
- Boom elevation: -3° to 78°

Auxiliary Lifting Sheave – Optional

- Single 419mm (16.5 in) root diameter nylon sheave
- Easily removable wire rope guards
- Does not affect erection of the fly or use of the main head sheaves

Hook Blocks and Balls – Optional

- 22.7mt (25 ton) 1 sheave quick-reeve hook block with safety latch
- 45mt (50 ton) 3 sheave quick-reeve hook block with safety latch
- 70mt (77 ton) 5 sheave quick-reeve hook block with safety latch
- 8mt (8.8 ton) swivel hook ball with safety latch

Fly – Optional

- 10.7m (35 ft) one piece lattice fly, stowable, offsettable to 2° , 15° , 30° , and 45° . Maximum tip height is 48.2m (158 ft).
- 10.7–17.7m (35–58 ft) two piece bi-fold lattice fly, stowable, offsettable to 2° , 15° , 30° , and 45° . Maximum tip height is 55.0m (180 ft 5 in).

Fly Inserts – Optional

- One 4.9m (16 ft) lattice insert, equipped with two 419mm (16.5 in) root diameter nylon sheaves, to be mounted between the boom head and fly options. Maximum tip height is 59.7m (196 ft).
- Two 4.9m (16 ft) lattice inserts, one equipped with two 419mm (16.5 in) root diameter nylon sheaves, to be mounted between the boom head and fly options. Maximum tip height is 64.5m (211 ft 7 in).

■ Operator's Cab and Controls

Environmental Cab – Fully enclosed, one person cab of galvaneal steel structure with acoustical insulation
Equipped with:

- Tinted and tempered glass windows
- Extra-large fixed front window with windshield wiper and washer
- Emergency exit roof window with windshield wiper
- Sliding left side door with large fixed window
- Sliding rear and right side windows for ventilation
- Six way adjustable, cushioned seat with seat belt and storage compartment
- Diesel fired warm-water heater with air ducts for front windshield defroster and cab floor
- Defroster fan for the front window
- Bubble level
- Circulating fan
- Adjustable sun visor
- Dome light
- Cup holder
- Fire extinguisher located on outside rear cab wall
- Left side viewing mirror
- Two position travel swing lock
- First aid kit

Air Conditioning – Optional – Integral with cab heating system utilizing the same ventilation outlets

Engine Dependent Heater – Optional – Flameless, warm-water system that does not have a separate fuel tank

Steering Column – Pedestal type with tilt and telescope functions for operator comfort. Column includes the following controls and indicators:

Left and right levers include:

- Horn button
 - Turn signal switch
 - Driving light switch
 - Transmission direction switch
- Panel mounted switches for:

- Travel park brake
- Steer mode selector
- 2/4 wheel drive/range selector
- Transmission gear selector

- Hazard flasher

Panel mounted indicator/warning lights for:

- Transmission temperature
- Engine oil pressure
- Travel park brake
- Service brake
- Turn signals
- Rear wheel offset
- Emergency steer

Armrest Controls – Two dual axis hydraulic joystick controllers or optional single axis hydraulic controllers for:

- Swing
- Boom hoist
- Main rear winch
- Auxiliary front winch – optional
- Drum rotation indication
- Drum rotation indicator activation switch
- Winch high/low speed and disable switch(es)
- Third wrap calibration switches
- Telescopic override switches
- Warning horn button
- Swing park brake
- Override key switch

Outrigger Controls – Hand held control box with umbilical cord gives the operator the freedom to view operation while setting the outriggers.

Foot Controls

- Boom telescope
- Swing brake
- Engine throttle
- Service brake

Right Front Console – Controls and indicators for:

- | | |
|--|---|
| • Engine ignition | • Check engine, stop engine, and wait to start indicators |
| • Engine throttle lock | • Console dimmer switch |
| • Function disable | • Bubble level |
| • Front windshield wiper and washer | • 12 volt power connection |
| • Cab floodlights | • Air conditioning – optional |
| • Heating controls | • Boom floodlight – optional |
| • Emergency travel brake switch | • Rotating beacon/Strobe light – optional |
| • Emergency stop switch | |
| • Third wrap and first layer indicator | |

Cab Instrumentation – Ergonomically positioned, analog instrumentation for crane operation including:

- Engine coolant temperature with warning indicator
- Hydraulic oil temperature with warning indicator
- Fuel level with warning indicator
- Tachometer
- Transmission temperature with warning indicator
- Voltmeter with warning indicator

Rated Capacity Limiter – Microguard graphic audio–visual warning system integrated into the dash with anti–two block and function limiter. Operating data available includes:

- Crane configuration
- Boom length and angle
- Boom head height
- Allowed load and % of allowed load
- Boom angle
- Radius of load
- Actual load
- Operator settable alarms (include):
 - Maximum and minimum boom angles
 - Maximum tip height
 - Maximum boom length
 - Swing left/right positions
 - Operator defined area (imaginary plane)

Internal RCL Light Bar – Optional – Visually informs the operator when crane is approaching maximum load capacity with a series of green, yellow, and red lights.

External RCL Light Bar – Optional – Visually informs the ground crew when crane is approaching maximum load capacity with a series of green, yellow, and red lights.

■ Swing

Motor/Planetary – Bi–directional hydraulic swing motor mounted to a planetary reducer for 360° continuous smooth swing at 2.0 rpm

Swing Park Brake – 360°, electric over hydraulic, (spring applied/hydraulic released) multi–disc brake mounted on the speed reducer. Operated by a switch from the operator’s cab.

Swing Brake – 360°, foot operated, hydraulic applied disc brake mounted to the speed reducer

Swing Lock – Two–position swing lock (boom over front or rear) operated from the operator’s cab

■ Electrical

Swing Alarm – Audio warning device signals when the upper is swinging.

Lights

- Two working lights on front of the cab
- One rotating amber beacon on top of the cab – optional
- One amber strobe beacon on top of the cab – optional
- Boom floodlight – optional

■ Load Hoist System

Load Hoist Performance

Main (Rear) and Auxiliary (Front) Winches – 19mm (3/4 in) Rope										
Layer	Maximum Line Pull		Normal Line Speed		High Line Speed		Layer		Total	
	kN	lb	m/min	ft/min	m/min	ft/min	m	ft	m	ft
1	75.10	16,883	55.7	183	98.1	322	26.2	86	26.2	86
2	67.85	15,253	61.8	203	108.5	356	29.3	96	55.5	182
3	61.87	13,910	67.6	222	118.9	390	32.0	105	87.5	287
4	56.87	12,785	73.7	242	129.5	425	34.7	114	122.2	401
5	52.61	11,828	79.5	261	139.9	459	37.5	123	159.7	524
6	---	---	---	---	---	---	40.5	133	200.3	657

Wire Rope Application		Diameter		Type	Maximum Permissible Load	
		mm	in		kN	lb
Main (Rear) Winch	Standard	19	3/4	6x19 IWRC – right regular lay (Type DB)	74.46	16,740
	Optional	19	3/4	18x19 rotation resistant – right regular lay (Type RB)	57.65	12,960
	Optional	19	3/4	36x7 rotation resistant – right regular lay (Type ZB)	69.48	15,619
Auxiliary (Front) Winch	Standard	19	3/4	6x19 IWRC – right regular lay (Type DB)	74.46	16,740
	Optional	19	3/4	18x19 rotation resistant – right regular lay (Type RB)	57.65	12,960
	Optional	19	3/4	36x7 rotation resistant – right regular lay (Type ZB)	69.48	15,619

2M Main and Optional Auxiliary Winches

- Axial piston, full and half displacement (2-speed) motors driven through planetary reduction unit for positive control under all load conditions
- Grooved lagging
- Power up/down mode of operation
- Drum rotation indicator(s)
- Drum diameter: 330mm (13 in)
- Rope length:
 - Front: 152.4m (500 ft)
 - Rear: 182.9m (600 ft)
- Maximum rope storage: 200.3m (657 ft)
- Terminator style socket and wedge
- Hoist drum cable followers

■ Hydraulic System

Counterbalance Valves – All hoist motors, boom extend cylinders, and boom hoist cylinders are equipped with counterbalance valves to provide load lowering and prevents accidental load drop when hydraulic power is suddenly reduced.

■ Counterweight

Total of 5 443kg (12,000 lb) of counterweight pinned to the upper structure frame with capacities for the 5 443kg (12,000 lb) configuration

Carrier

■ General

- 3.23m (10 ft 7 in) wide
- 4.45m (14 ft 7 in) wheelbase (centerline of first axle to centerline of second axle)

Frame – Box-type, torsion resistant, welded construction made of high tensile steel. Equipped with front and rear towing and tie-down lugs, tow connections, and access ladders.

■ Outriggers

Boxes – Two double box, front and rear welded to carrier frame

Beams and Jacks – Four single stage beams with Confined Area Lifting Capacities (CALC™) provide selectable outrigger extensions of full, intermediate, and retracted. Hydraulically controlled from the operator's cab with integral check valves.

Pontoons – Four lightweight, quick release, 597 x 597mm (23.5 x 23.5 in), steel pontoons with contact area of 2 968cm² (460 in²) can be stored for road travel in storage racks on the carrier.

Main Jack Reaction – 41 050kg (90,500 lb) force and 1 358kPa (197 psi) ground bearing pressure

■ Steering and Axles

Steering – Four independent modes consisting of two wheel front, two wheel rear, four wheel, and crab. Each mode is controlled from the steering wheel and is selected by a switch in the operator's cab.

Drive – Two modes: 4 x 2 and 4 x 4 for off highway travel

Axle 1 – Steered, non-driven for 4 x 2 and steered, driven for 4 x 4

Axle 2 – Steered, driven

■ Suspension

Front – Rigid mount to the carrier frame

Rear – The rear axle is suspended on the oscillation cylinders with motion of the axle controlled by a four bar linkage system. The oscillation cylinders lockout when the upper structure rotates 2.5° past centerline.

- Hydro-gas rear suspension – optional

■ Tires and Wheels

Front and Rear – Four (single) 26.5 x 25–26 ply rating, earthmover type tires on steel disc wheels

- Spare tires and wheels – optional

■ Brakes

Service – Full hydraulic, dual circuit, disc type brakes on all wheel ends

Parking/Emergency – Spring applied type, acting on front axle

■ Electrical

Two batteries provide 12 volt starting and operation

Lights

- Front lighting includes two main headlights and two parking/directional indicators.
- Side lighting includes two parking/directional indicators per side.
- Rear lighting includes two parking/directional indicators, two parking/brake lights, and two reversing lights.
- Other equipment includes hazard/warning system, cab light, instrument panel light, and signal horn.

■ Engine

Specification	CAT C6.6
Emissions compliance	EU Stage IIIA ⁽¹⁾
Numbers of Cylinders	6
Cycle	4
Bore and Stroke: mm (inch)	105 x 127 (4.13 x 5.00)
Piston Displacement: L (in ³)	6.6 (403)
Max. Brake Horsepower: kW (hp)	175.2 (235) @ 2,000 rpm
Peak Torque: Nm (ft lb)	986 (727) @ 1,400 rpm
Alternator: volts – amps	12 – 150
Crankcase Capacity: L (qt)	17.4 (18.4)
<ul style="list-style-type: none"> • Mechanically driven fan and thermostatically controlled radiator 	
(1) Complies with EU Stage IIIA standards effective January 2007.	

■ Transmission

Powershift – Three speed with high/low range for 5 forward and 5 reverse gears. Front axle disconnect for two or four wheel drive. Front axle disconnects in high range.

■ Carrier Speeds and Gradeability

Spicer		Ratio	Speed		Gradeability (@ stall)
Gear			km/h	mph	% Grade
5th	Forward & Reverse 2WD/Hi	2.25	15.8	9.8	10.1
4th		4.67	7.7	4.8	23.5
3rd	Forward & Reverse 4WD/Low	2.4	14.8	9.2	10.9
2nd		6.54	5.6	3.5	34.8
1st		13.6	2.7	1.7	99.5

Based on a gross vehicle weight of 39 916kg (88,000 lb).

Crane operating angle must not exceed 35° (77% grade).

■ Fuel Tank

One 283.9L (75 gallon) capacity tank

■ Hydraulic System

All functions are hydraulically powered allowing positive precise control with independent or simultaneous operation of all functions.

Main Pumps

- One two section fixed displacement gear pump for the front/rear winches and boom hoist circuits.
- One two section fixed displacement gear pump for the swing/telescope, power steering/outrigger/telescope, service brake, and oscillation circuits.
- Combined pump capacity of 522.4Lpm (138 gpm)

Hydraulic Reservoir – 579.2L (153 gal) capacity equipped with sight level gauge. Diffusers built in for deaeration.

Filtration – One 10 micron, full flow line filter in the control circuit. All oil is filtered prior to return to reservoir. Accessible for easy filter replacement.

■ Pump Drive

All pumps are mounted on the transmission and mechanically driven by the diesel engine.

- Front/rear winches and boom hoist pumps can be disconnected with a manual pump disconnect to aid in cold weather starting – optional.

Axle Loads

Base crane with full tank of fuel	Gross Vehicle Weight ⁽¹⁾		Upper Facing Front				Upper Facing Rear			
			Front Axles		Rear Axles		Front Axles		Rear Axles	
	kg	lb	kg	lb	kg	lb	kg	lb	kg	lb
	38 555	84,999	18 407	40,580	20 148	44,419	16 787	37,009	21 768	47,990
Pintle hook, front	6	13	7	16	-2	-4	7	16	-2	-4
Pintle hook, rear	6	13	-2	-5	8	17	-2	-5	8	17
Rear steer indicator	3	6	0	0	3	6	0	0	3	6
Hydro-gas suspension	22	48	8	17	14	31	8	17	14	31
Pump disconnect	18	39	3	7	15	32	3	7	15	32
Operator in cab	113	250	61	134	53	116	47	103	67	147
Auxiliary winch with 152.4m (500 ft) wire rope	244	538	-45	-100	289	638	277	610	-33	-72
Hoist drum follower – auxiliary	30	67	-8	-17	38	84	36	80	-6	-13
Substitute type “DB” rope with type “RB” rope – main winch	57	126	-20	-44	77	170	74	164	-17	-38
Substitute type “DB” rope with type “RB” rope – auxiliary winch	48	105	-9	-19	56	124	54	119	-6	-14
Substitute 152.4m (500 ft) wire rope with 182.9m (600 ft) – auxiliary	47	104	-9	-19	56	123	54	118	-6	-14
Remove 182.9m (600 ft) wire rope from rear (main) winch	-291	-642	103	226	-394	-868	-377	-835	88	193
Remove 152.4m (500 ft) wire rope from front (auxiliary) winch	-244	-538	45	100	-289	-638	-277	-610	33	72
Air conditioning	100	220	26	57	74	163	69	152	31	68
Floodlight to front of boom base section	3	7	6	13	-3	-6	-3	-6	6	13
Fly mounting brackets to boom base section for fly options	80	176	143	316	-63	-140	-67	-149	147	325
10.67m (35 ft) offsettable fly – stowed	722	1,591	1 136	2,504	-414	-913	-451	-995	1 173	2,586
10.67 – 17.68m (35 – 58 ft) offsettable fly – stowed	1 026	2,263	1 434	3,162	-408	-899	-461	-1,016	1 487	3,279
Auxiliary lifting sheave	50	110	135	297	-85	-187	-88	-193	137	303
70mt (77 ton) 5–sheave hook block at bumper	635	1,400	936	2,064	-301	-664	-334	-736	969	2,136
45mt (50 ton) 3–sheave hook block at bumper	466	1,027	687	1,514	-221	-487	-245	-540	711	1,567
22.7mt (25 ton) 1–sheave hook block at bumper	337	742	496	1,094	-160	-352	-177	-390	513	1,132
8mt (8.8 ton) hook ball at bumper	244	538	360	793	-116	-255	-128	-283	372	821
70mt (77 ton) 5–sheave hook block at boom head	635	1,400	1 651	3,640	-1 016	-2,240	-1 049	-2,312	1 684	3,712
45mt (50 ton) 3–sheave hook block at boom head	466	1,027	1 211	2,670	-745	-1,643	-769	-1,696	1 235	2,723
22.7mt (25 ton) 1–sheave hook block at boom head	337	742	875	1,929	-538	-1,187	-556	-1,225	892	1,967
8mt (8.8 ton) hook ball at boom head	244	538	635	1,399	-391	-861	-403	-888	647	1,426

Tire	Maximum Allowable Axle Load @ 40.2km/h (25 mph)
26.5 x 25	23 151kg (51,040 lb)

(1) Adjust gross vehicle weight and axle loading according to component weight.

Note: All weights are ±3%.

General Dimensions

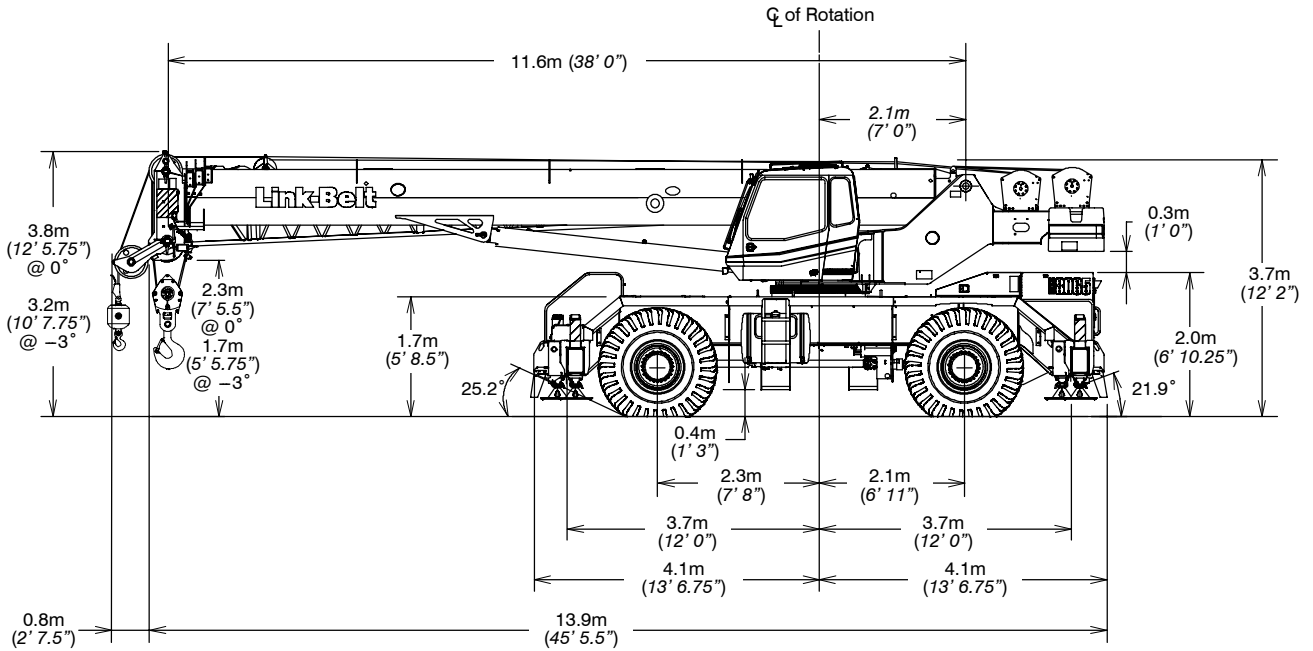

Turning Radius – Front Wheel (4x2) Steering		
	Metric	English
Wall to wall over carrier	13.2m	43' 2"
Wall to wall over boom attachment	16.3m	53' 4"
Curb to curb	12.6m	41' 6"
Centerline of tire	12.2m	40' 1"

Turning Radius – All Wheel (4x4) Steering		
	Metric	English
Wall to wall over carrier	8.1m	26' 6"
Wall to wall over boom attachment	11.6m	38' 1"
Curb to curb	7.6m	24' 10"
Centerline of tire	7.2m	23' 6"

Tail Swing		
	Metric	English
With counterweight	4.2m	13' 8.25"
Without counterweight	N/A	N/A

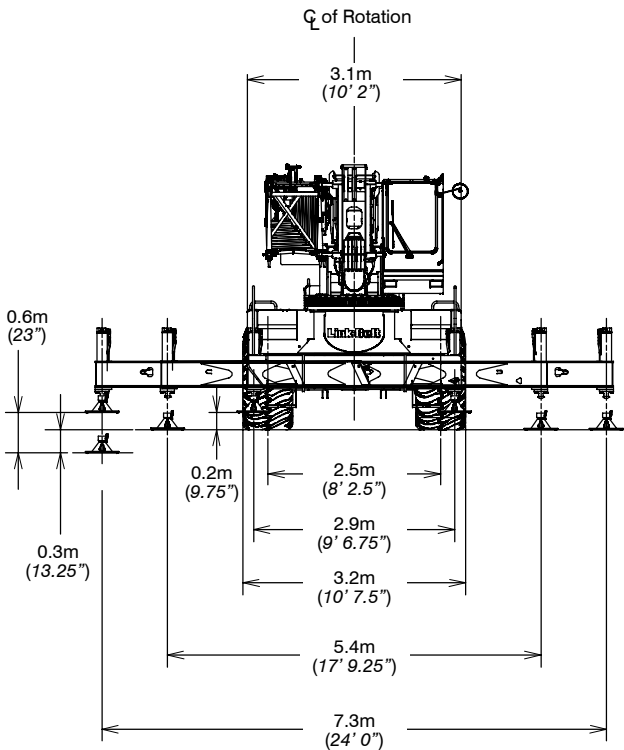

Not To Scale

Working Range Diagram

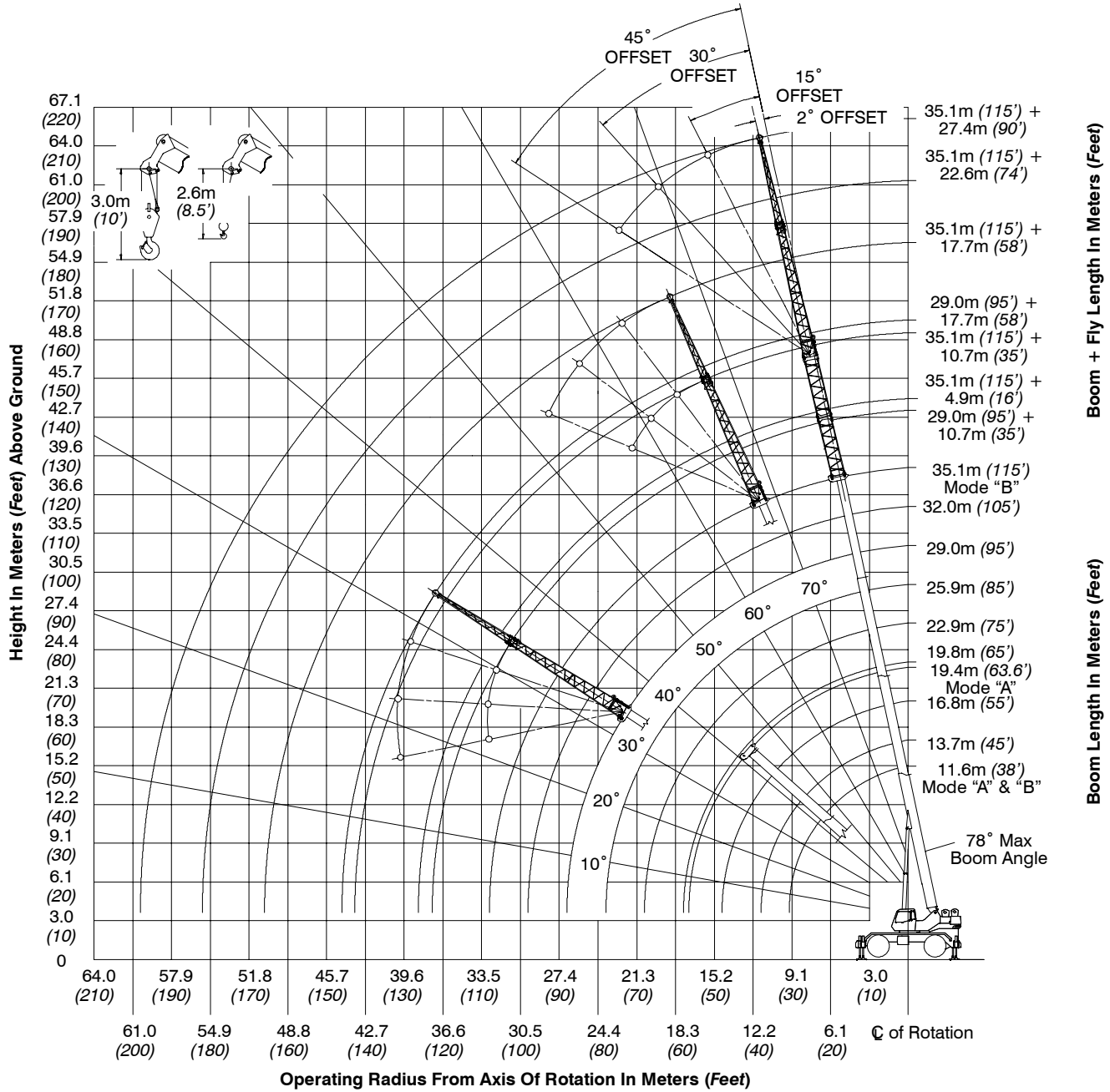

Boom Extend Modes

Boom Mode "A" (A-max)

Only inner mid section telescopes.

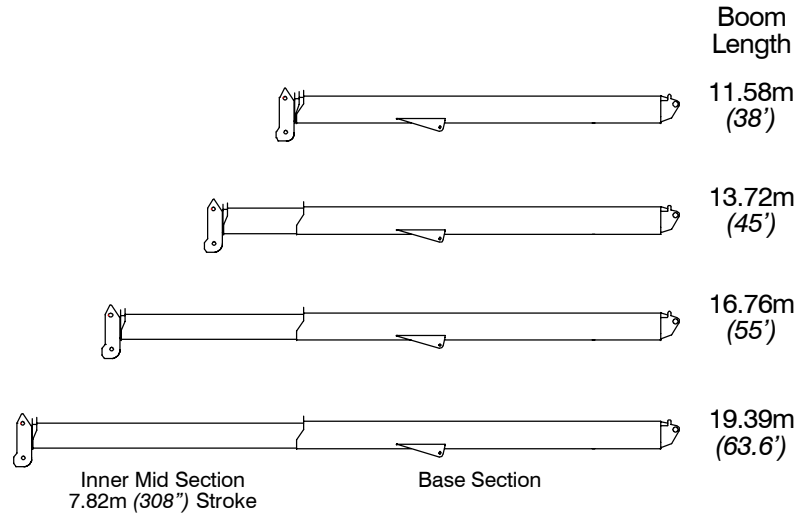

Boom Mode "B" (Standard)

Inner mid, outer mid, and tip sections telescope simultaneously.

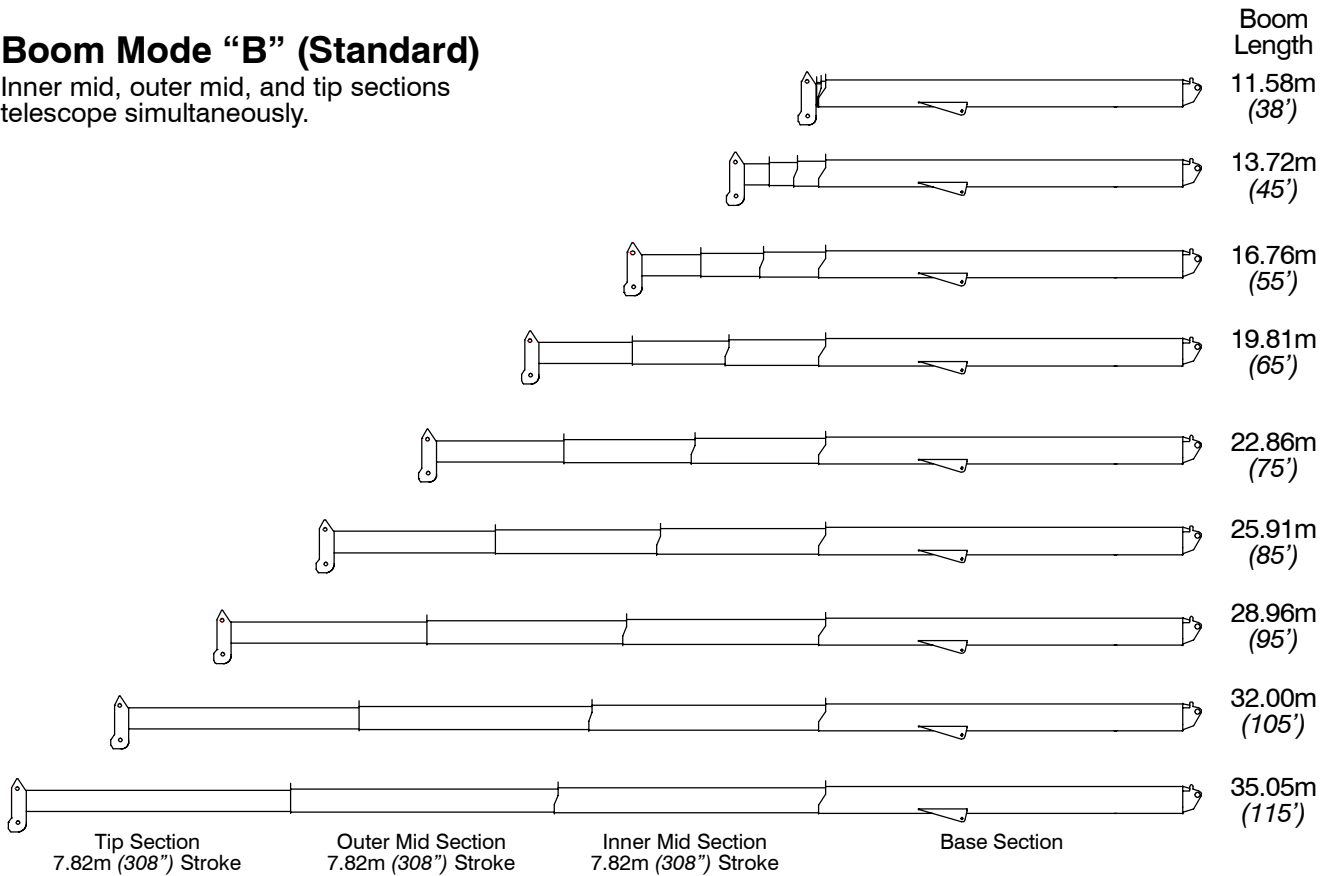

Main Boom Lift Capacity Charts – Standard

Fully Extended Outriggers – 360° Rotation (All Capacities Are Listed In Kilograms)										
Radius (m)	Boom Length (m)									Radius (m)
	11.58	13.7	16.8	19.39/19.8	22.9	25.9	29.0	32.0	35.05	
2.5	60 000									2.5
3	54 800	49 000	48 100							3
3.5	50 650	48 650	45 550	32 600**						3.5
4	46 900	45 250	42 300	32 600**						4
4.5	42 250	42 050	39 500	32 600**	24 450					4.5
5	37 800	37 600	37 100	32 600**	24 450					5
6	31 000	30 850	30 650	30 500**	24 450	25 550	21 150			6
7	26 050	25 900	25 750	25 650**	24 450	23 700	19 750			7
8	22 300	22 600	22 850	23 000	23 100	22 050	18 500	16 400	12 800	8
9	19 050	19 450	19 700	19 850	19 950	20 050	17 300	15 650	12 800	9
10		15 750	16 050	16 200	16 300	16 350	16 150	14 550	12 800	10
12			11 350	11 500	11 600	11 600	11 650	11 700	11 700	12
14			8 400	8 550	8 650	8 750	8 800	8 800	8 850	14
16				6 600	6 700	6 750	6 800	6 850	6 850	16
18					5 300	5 400	5 450	5 450	5 500	18
20					4 200	4 300	4 350	4 400	4 450	20
22						3 450	3 500	3 550	3 600	22
24							2 850	2 900	2 900	24
26							2 250	2 300	2 350	26
28								1 850	1 900	28
30									1 500	30
32									1 150	32

** 19.39 A – max Mode

This information is not for crane operation. Operator must refer to the in-cab information for crane operation. Rated lifting capacities shown meet ISO 4305 standards.

On Tires – Stationary – Boom Centered Over Front Between Tire Tracks (All Capacities Are Listed In Kilograms)							
Radius (m)	Boom Length (m)						Radius (m)
	11.58	13.7	16.8	19.8	22.9	25.9	
3	29 000						3
3.5	26 500						3.5
4	24 200	24 050					4
4.5	22 250	22 450	17 900				4.5
5	20 550	20 750	17 900				5
6	17 700	17 950	17 900	13 750			6
7	14 950	15 250	15 550	13 750			7
8	11 700	12 050	12 250	12 400	10 150		8
9	9 300	9 650	9 950	10 050	10 150	7 800	9
10		7 900	8 200	8 350	8 400	7 800	10
12			5 750	5 900	6 000	6 050	12
14			4 100	4 300	4 450	4 500	14
16				3 150	3 300	3 350	16
18					2 400	2 500	18
20					1 750	1 850	20
22						1 300	22

This information is not for crane operation. Operator must refer to the in-cab information for crane operation. Rated lifting capacities shown meet ISO 4305 standards.

On Tires – Pick & Carry (Creep) – Boom Centered Over Front
(All Capacities Are Listed In Kilograms)

Radius (m)	Boom Length (m)						Radius (m)
	11.58	13.7	16.8	19.8	22.9	25.9	
3	28 550						3
3.5	25 900						3.5
4	23 400	23 550					4
4.5	21 250	21 450	17 900				4.5
5	19 400	19 600	17 900				5
6	16 400	16 650	16 850	13 750			6
7	14 050	14 300	14 500	13 750			7
8	11 700	12 050	12 250	12 400	10 150		8
9	9 300	9 650	9 950	10 050	10 150	7 800	9
10		7 900	8 200	8 350	8 400	7 800	10
12			5 750	5 900	6 000	6 050	12
14			4 100	4 300	4 450	4 500	14
16				3 150	3 300	3 350	16
18					2 400	2 500	18
20					1 750	1 850	20
22						1 300	22

On Tires – Stationary – 360° Rotation
(All Capacities Are Listed In Kilograms)

Radius (m)	Boom Length (m)						Radius (m)
	11.58	13.7	16.8	19.8	22.9	25.9	
3	21 950						3
3.5	18 750	19 000					3.5
4	14 950	15 200					4
4.5	12 200	12 450	12 650				4.5
5	10 100	10 450	10 650				5
6	7 250	7 550	7 800	7 900			6
7	5 300	5 600	5 850	6 000			7
8	3 950	4 250	4 500	4 700	4 800		8
9	2 900	3 200	3 500	3 650	3 800	3 850	9
10		2 400	2 650	2 850	2 950	3 050	10
12			1 500	1 650	1 800	1 900	12
14			650	850	950	1 050	14
16						450	16

This information is not for crane operation. Operator must refer to the in-cab information for crane operation. Rated lifting capacities shown meet ISO 4305 standards.

Fly Attachment Lift Capacity Charts – Optional

Fully Extended Outriggers – 360° Rotation (All Capacities Are Listed In Kilograms)									
35.05 m Main Boom Length 2° Fly Offset					35.05 m Main Boom Length 15° Fly Offset				
Radius (m)	Fly Length (m)				Radius (m)	Fly Length (m)			
	10.67	17.68	22.56	27.43		10.67	17.68	22.56	27.43
12	5 900				12				
14	5 900	4 000			14	5 350			
16	5 750	3 850	3 250		16	5 150			
18	5 600	3 750	3 250	2 500	18	5 000			
20	4 850	3 600	3 150	2 400	20	4 850	3 100	2 650	
22	3 950	3 450	2 900	2 200	22	4 250	3 000	2 450	1 950
24	3 250	3 300	2 650	2 000	24	3 550	2 850	2 300	1 800
26	2 700	2 950	2 450	1 850	26	2 950	2 750	2 150	1 650
28	2 250	2 450	2 300	1 700	28	2 400	2 650	2 000	1 500
30	1 850	2 050	2 050	1 550	30	2 000	2 350	1 850	1 400
32	1 500	1 700	1 650	1 400	32	1 650	1 950	1 750	1 300
34	1 200	1 400	1 350	1 300	34	1 300	1 650	1 550	1 200
36	900	1 150	1 100	1 100	36	1 050	1 350	1 300	1 100
38	700	900	850	850	38	800	1 050	1 000	1 000
40	500	700	650	650	40	550	850	800	800
42		500	450	450	42		650	600	600
44					44		450	400	400

This information is not for crane operation. Operator must refer to the in-cab information for crane operation. Rated lifting capacities shown meet ISO 4305 standards.

Fully Extended Outriggers – 360° Rotation (All Capacities Are Listed In Kilograms)									
35.05 m Main Boom Length 30° Fly Offset					35.05 m Main Boom Length 45° Fly Offset				
Radius (m)	Fly Length (m)				Radius (m)	Fly Length (m)			
	10.67	17.68	22.56	27.43		10.67	17.68	22.56	27.43
18	4 450				18				
20	4 300				20	4 000			
22	4 200				22	3 950			
24	3 800	2 500			24	3 900			
26	3 150	2 400	1 800	1 450	26	3 300	2 200		
28	2 600	2 350	1 700	1 350	28	2 750	2 150	1 550	
30	2 150	2 300	1 600	1 250	30	2 250	2 150	1 450	1 150
32	1 750	2 250	1 550	1 150	32	1 850	2 100	1 400	1 050
34	1 400	1 850	1 450	1 050	34	1 450	2 050	1 350	1 000
36	1 100	1 550	1 400	1 000	36		1 650	1 300	900
38	850	1 250	1 250	900	38		1 350	1 250	850
40	600	1 000	950	850	40		1 050	1 100	800
42		750	750	750	42		800	850	750
44		550	550	550	44			600	650
46					46			400	450

This information is not for crane operation. Operator must refer to the in-cab information for crane operation. Rated lifting capacities shown meet ISO 4305 standards.

This Page Intentionally Blank

Link-Belt Construction Equipment Company Lexington, Kentucky www.linkbelt.com

®Link-Belt is a registered trademark. Copyright 2010. We are constantly improving our products and therefore reserve the right to change designs and specifications.